

# Horizontal Loading and Positioning Table (TPCH attachment)

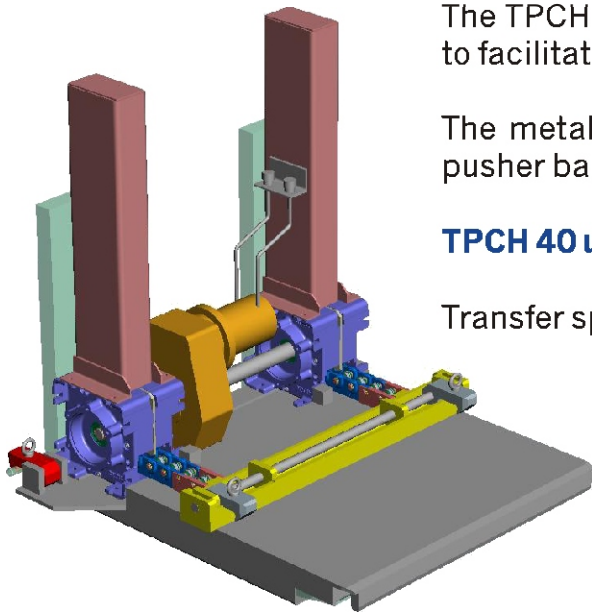

The TPCH is a fork lift truck attachment, for adapting onto the forks, to facilitate the positioning of press tools on presses.

The metal pallet is fitted with a motorised push/pull system. The pusher bar is designed to interface with the tools.

**TPCH 40 up to 2 tonnes - TPCH 60 up to 4 tonnes**

Transfer speed **Steel on Steel 50 mm:/s**

## ADVANTAGES :

- Detachable
- Safe
- Environmentally friendly
- Ergonomic
- Speeds up tool changes

## Complimentary equipment available as options :

- Installation kit for hydraulic supply to motor
- 2 pressure regulators for push/pull force control
- 2 flow control units for speed of tool transfer

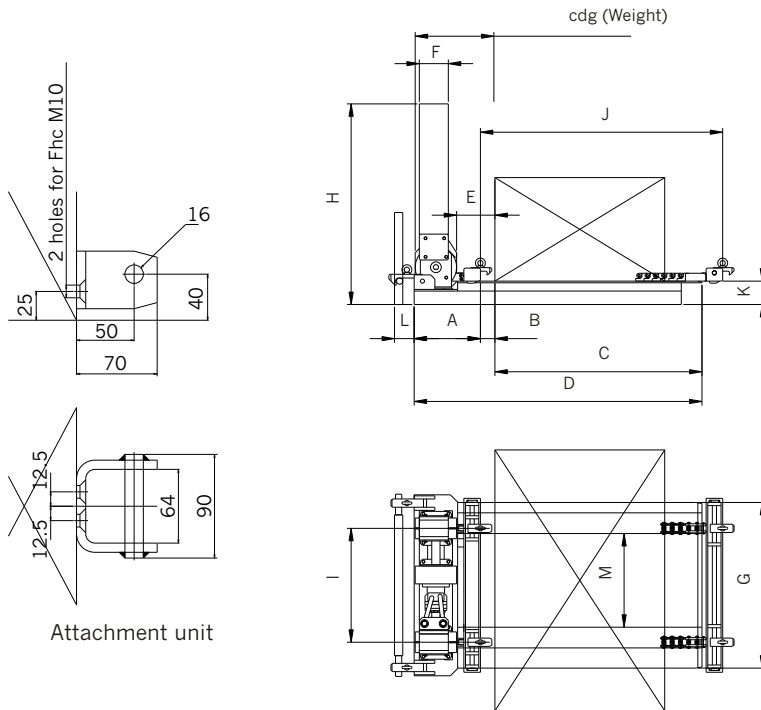

All dimensions are in mm

	TPCH 40 2000 kg maxi	TPCH 60 4000 kg maxi
A	320	390
B	70	70
C	1000	1200
D	1390	1660
E	185	185
F	100	200
G	700 800 900	900 1000 1100
H		1134
I	550 +/-50	750 +/-50
J	1100	1300
K	113*	113*
L	*	*
M	*	*
Cdg	380 (250 kg)	380 (400 kg)

\* : depends on the fork dimensions

## Designation for order :

**T.P.C.H.** 40  
Or  
60 S stroke in mm G width table L M

**Example : T.P.C.H. 40-1200-800-30-300**

[www.serapid.com](http://www.serapid.com)

SERAPID UK.

5, Brentwood Close, Littleborough  
Lancashire OL 15 0ND, UK  
Tel. +44 (0)170 637 62 30  
Fax +44 (0) 170 637 10 29

[info-uk@serapid.com](mailto:info-uk@serapid.com)

First edition - Révision A . SERAPID 08-2002  
Brand and product names are trademarks of their respective holders  
Subject to change