



**TAVOLE ROTANTI  
MECCANICHE  
MECHANICAL  
ROTARY TABLES**



# INDICE

## Index

CARATTERISTICHE DELLA TAVOLA <i>ROTARY INDEX TABLE FEATURES</i>	3
DESCRIZIONE GENERALE <i>GENERAL DESCRIPTION</i>	4
PRINCIPIO DI FUNZIONAMENTO <i>PRINCIPLE OF OPERATION</i>	5
RIFERIMENTI DI FASE E MICROINTERRUTTORE DI FASE <i>CAM SETTING REFERENCES AND SET MICROSWITCH</i>	6
STAZIONI E ANGOLO DI TRASFERIMENTO <i>INDEX NUMBER AND CAM TRANSFER ANGLES</i>	7
DATI TECNICI <i>TECHNICAL DATA</i>	9
DIMENSIONI DI INGOMBRO <i>DIMENSION DRAWINGS</i>	14
FORI PER L'ASSEMBLAGGIO SUL DISCO TAVOLA <i>HOLES FOR TOP PLATE ASSEMBLY</i>	18
DIMENSIONI CAMMA E MICRO DI FASE <i>OVERALL DIMENSIONS OF CAM /SET MICROSWITCH</i>	19
POSIZIONE DI LAVORO TAVOLA ROTANTE <i>INDEX TABLE OPERATING POSITION</i>	20
POSIZIONE DI MONTAGGIO MOTORIDUTTORE <i>POWER DRIVE UNIT ASSEMBLING POSITION</i>	20
RIDUTTORI E MOTORI <i>DRIVE UNITS AND MOTORS</i>	21



Tutte le tavole meccaniche G.P.A. possono essere abbinare alle presse pneumatiche ed idropneumatiche G.P.A. per creare sistemi ad alta cadenza di lavoro, come nelle foto seguenti dove sono mostrate macchine con presse da 20 a 70 kN.

*All G.P.A. mechanical rotary tables can be combined to G.P.A. pneumatic and hydropneumatic presses to make available high working frequency systems, as in the pictures herebelow, where machines with presses from 20 to 70 kN are shown.*

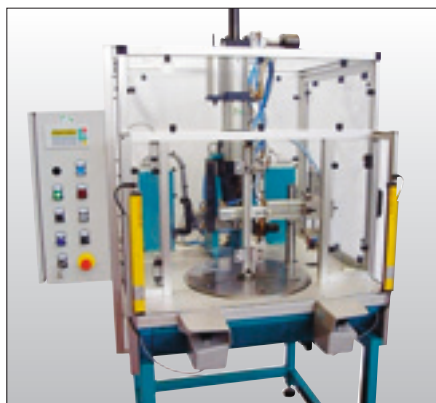

# CARATTERISTICHE DELLA TAVOLA ROTANTE

## *Rotary index table features*

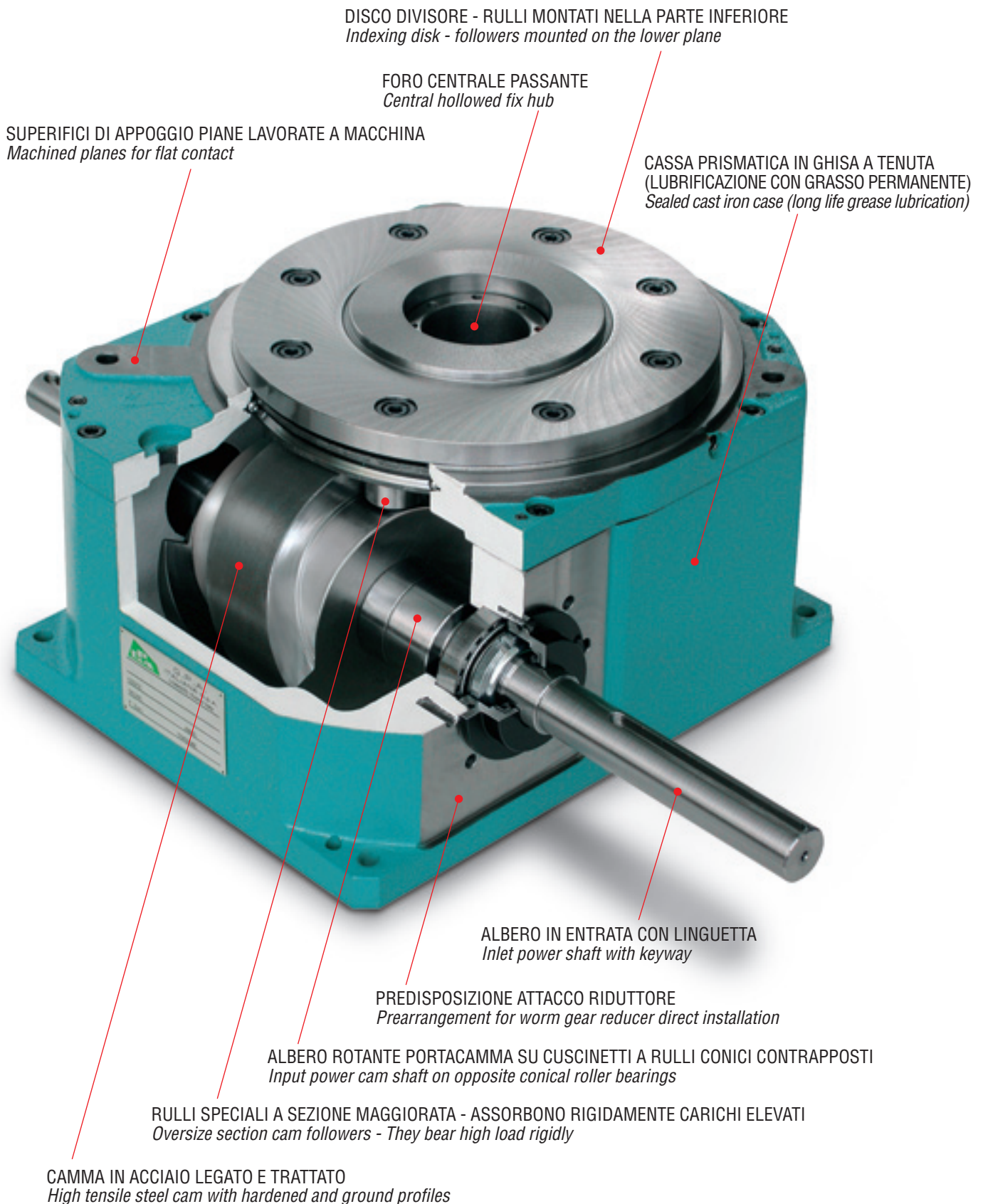



# DESCRIZIONE GENERALE

## *General description*

### **ROTAZIONE CONTROLLATA**

G.P.A. ha sviluppato le tavole rotanti meccaniche serie TA per il trasferimento di pezzi con la massima velocità possibile. L'affidabilità e le prestazioni di queste attrezzature sono il frutto dell'esperienza acquisita e della costante ricerca tecnologica di soluzioni migliori.

#### **PERCHÉ ROTANTE E INTERMITTENTE**

Quando le necessità sono: produttività, velocità, precisione, silenziosità e basso costo di esercizio, l'esperienza ha dimostrato che il sistema intermittente meccanico governato da camma è il più indicato.

#### **TAVOLA ROTANTE SERIE TA**

La TAVOLA ROTANTE G.P.A. serie TA è una unità meccanica ad assi ortogonali che trasforma la rotazione uniforme dell'albero in entrata in rotazione intermittente del disco in uscita. Questo si ottiene con una camma a tamburo che trascina due o più rulli fissi sul disco.

Il numero delle divisioni standard è da 2 a 32. Altre fino a 540 sono disponibili a richiesta.

Le tavole rotanti sono estremamente diffuse ed applicate su attrezzature quali:

- Sistemi di assemblaggio
- Linee di confezionamento
- Attrezzature di produzione
- Macchine di saldatura automatica
- Dispositivi di trasporto
- Isole di lavorazione
- Macchine di imbottigliamento
- Macchine di stampa

#### **VANTAGGI**

I principali vantaggi sono:

- Movimento veloce e progressivo interamente controllato
- Regolarità di funzionamento anche ad alta frequenza.
- Posizione di arresto autobloccata
- Alta ripetibilità
- Assenza di vibrazioni
- Manutenzione minima
- Minima potenza installata

### **CONTROLLED INDEXING**

*G.P.A. has developed the series TA rotary index tables for pieces transfer with the maximum possible speed. Reliability and performance of these equipments stem from our experience and unending research for better technological solutions.*

#### **WHY ROTATING AND INTERMITTENT**

*When requirements are: productivity, high speed, accuracy, low noise, low running cost, experience has clearly shown that the mechanical rotary intermittent system is the answer.*

#### **ROTARY INDEXING TABLE SERIES TA**

*G.P.A. ROTARY INDEXING TABLE series TA is a mechanical square axis unit to transform the uniform rotation of inlet shaft in an intermittent rotation of output disk.*

*The number of standard indexings ranges from 2 up to 32. From 32 up to 540 indexings on request.*

*Indexing tables are generally mounted on:*

- *Assembling machines*
- *Packing equipments*
- *Manufacturing equipments*
- *Automated welding machines*
- *Movement devices*
- *Machining isles*
- *Filling machines*
- *Printing machines*

#### **ADVANTAGES**

*The main pros are:*

- *High speed continuous and totally controlled displacement*
- *Smooth running also at high frequency*
- *Self-locking in dwell position*
- *High repeatability*
- *Low maintenance*
- *Low installed power*

# PRINCIPIO DI FUNZIONAMENTO

## Principle of operation



La TAVOLA ROTANTE serie TA è un dispositivo meccanico ad assi ortogonali che, tramite una trasmissione a camma elicoidale e rulli in presa continua, trasforma il moto rotatorio uniforme dell' albero in entrata in una rotazione intermittente determinata in uscita.

Il profilo costruttivo della camma determina la rotazione del disco, con accelerazioni definite da funzioni matematiche, e la pausa per il tempo stabilito.

Il funzionamento è schematizzato qui sotto.

The ROTARY INDEXING TABLE series TA is a mechanical square axis device.

A mechanical cam with followers transforms the inlet shaft uniform rotation into a predetermined intermittent rotation at the outlet.

The cam shape causes the disk rotation, which follows mathematically set movement curves, and a well defined dwell period.

The principle of operation is shown below.

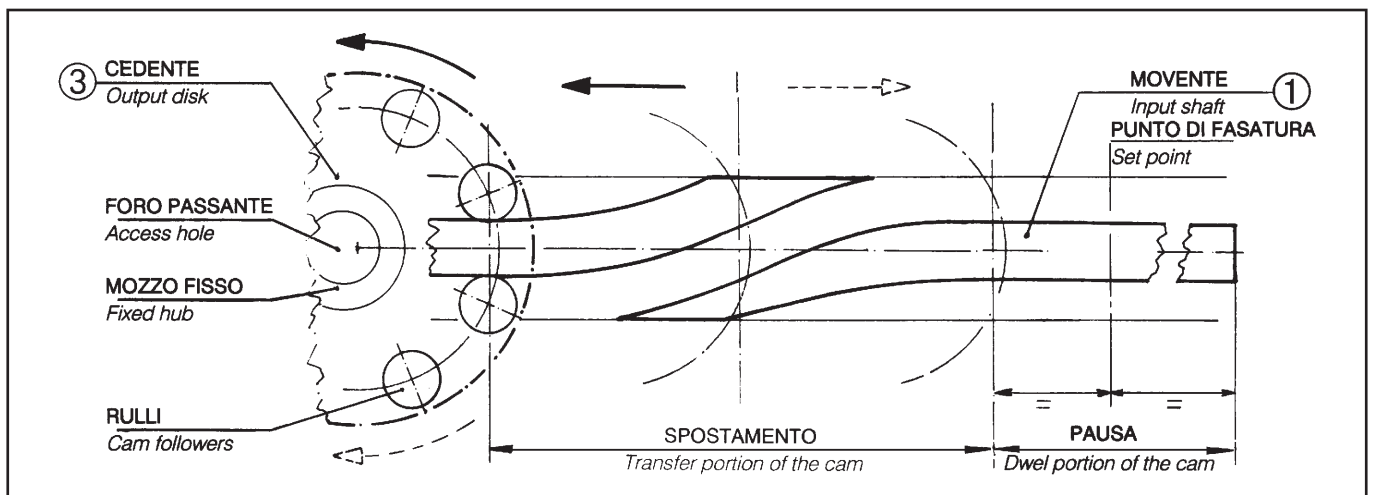

## DESCRIZIONE

### Description

Per ottenere un ciclo completo è necessaria la rotazione di 360° dell'albero in entrata con un movimento ed un periodo di sosta del disco in uscita. Questo risultato si ottiene con una camma a tamburo (1) - movente - ed un disco con dei rulli (3) - cedente - (vedi fig. a lato).

Quando la camma ruota, il profilo trascina in rotazione il disco a mezzo dei rulli, che rullano sulla camma in numero minimo di due.

Il disco portarulli è costantemente controllato per tutto il ciclo durante il movimento ed il periodo di pausa.

Durante il movimento la camma impone l'attuazione delle leggi di accelerazione e velocità definite in fase di progetto.

Durante la pausa il profilo della camma è ortogonale rispetto all'albero.

For a complete operating cycle it is necessary the full rotation (360°) of the input shaft with a transfer and a dwell period of the output indexing disk.

The cam rib (1) drives along its profiles the cam followers (3). (see picture on the left). As the cam followers are part of the index disk, when the cam rib rotates the engaged followers, which are always at least two, make the disk to move in an intermittent way. The index disk is constantly driven through the full cycle, during the transfer and the dwell portion.

During the transfer motion the engaged portion of the cam rib transmits to the disk the type of movement (with its peculiar acceleration and deceleration) which has been planned in the project.

During the dwell period the configuration of the engaged cam rib portion is square to the shaft.

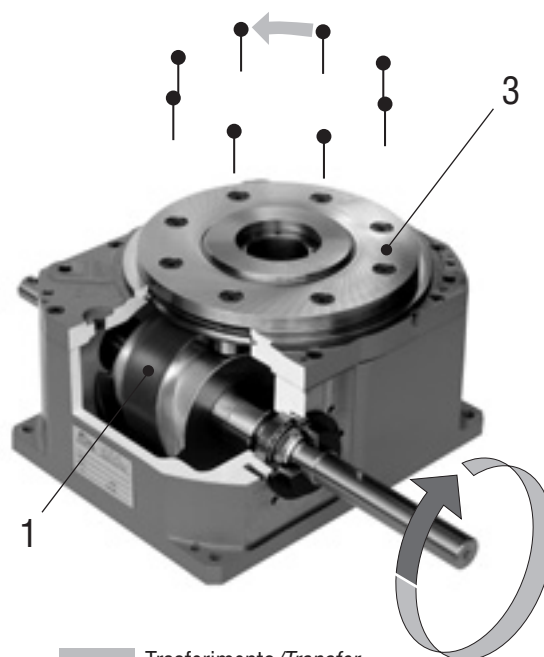

Trasferimento/Transfer  
Pausa/Dwell



## RIFERIMENTI DI FASE *Referring to set point*

L'albero portacamma di una tavola rotante standard è dotato di una linguetta che può essere utilizzata come riferimento di fase. Quando questa è in posizione superiore, a 90° gradi rispetto al piano d'appoggio, il meccanismo è situato a metà del periodo di pausa (vedi figura a lato pos. 1).

In caso di tavola rotante con camma a doppio profilo, quando la linguetta è in posizione superiore o inferiore, a 90° rispetto al piano di appoggio, il meccanismo è situato a metà del periodo di pausa. In questo caso il disco intermittente esegue due spostamenti e due pause con un solo giro dell'albero in ingresso (vedi fig. a lato pos. 2).

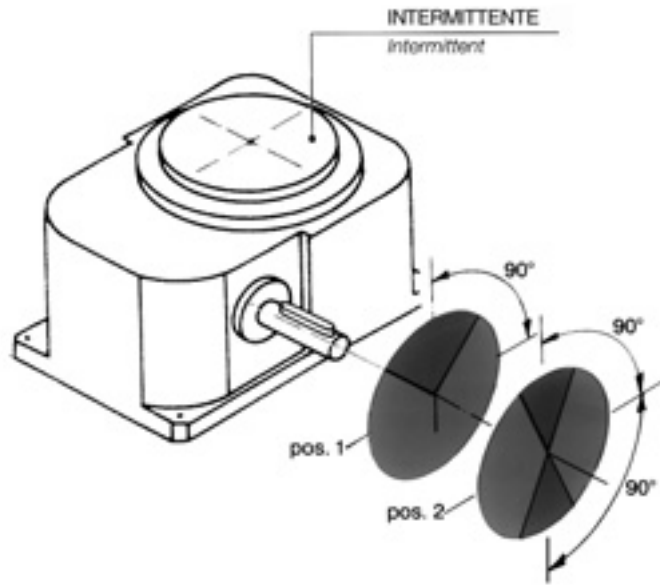

Rotating cam holder shaft of a standard rotary indexing table is equipped with a keyway which can be used as set point reference. When the keyway is in upper position, 90° to the table base, the indexing mechanism is exactly in the middle of the dwell (see picture here beside pos. 1).

In case of indexing table with double profile cam, when the keyway is in upper or lower position, 90° to the table base, the indexing mechanism is exactly located in the middle of the dwell. In this

particular case the output intermittent disk performs two transfer and two dwells with only one rotation of the inlet power camshaft (see picture here beside pos. 2).

## MICROINTERRUTTORE DI FASE *Set microswitch*

La tavola rotante può essere equipaggiata di microinterruttore azionato da camma sul prolungamento dell'albero in ingresso. Quando il periodo di pausa determinato dalla rotazione della camma non è sufficientemente lungo, l'impiego del micro-interruttore consente di controllare un motore autofrenante e di variare l'ampiezza della sosta in funzione delle esigenze.

La durata dell'arresto del disco intermittente viene quindi determinata regolando l'intervento del micro in posizione intermedia del periodo di pausa (vedi figura a lato).

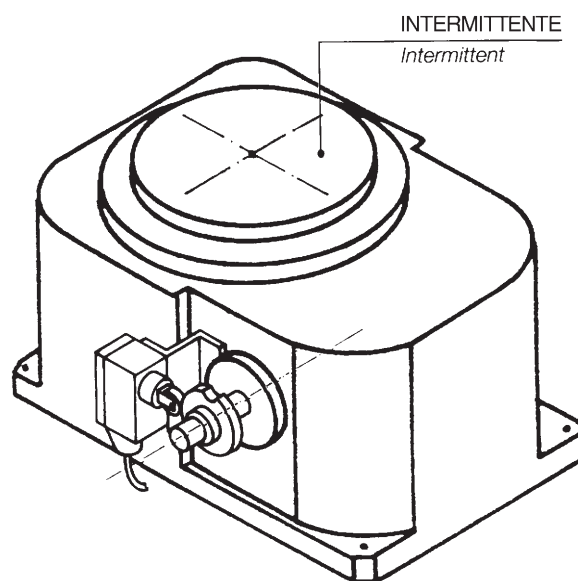

The rotary indexing table can also be equipped with a microswitch operated by a little cam on the rear part of the inlet power shaft. When the dwell period generated by the cam rotation is not long enough for operation's needs, said limit switch enables to stop and start an electric brake motor and thus to control the dwell time to meet the above needs. The microswitch is set to operate in the middle of the dwell period.

Dwell time of output intermittent disk can be easily regulated by setting cam and micro switch in an intermediate position of dwell (see picture here beside).

# STAZIONI E ANGOLI DI TRASFERIMENTO

## *Index number and cam transfer angles*



Divisioni Stations	Divisore Indexer	profili camma Cam profiles	Angoli impegnati per lo spostamento Cam rotation angle performing the transfer movements									
			90	120	150	180	210	240	270	300	315	330
<b>2</b>	TA 10	1										
	TA 15											
	TA 25											
	TA 35											
<b>3</b>	TA 10	1										
	TA 15											
	TA 25											
	TA 35											
<b>4</b>	TA 10	1										
	TA 15											
	TA 25											
	TA 35											
<b>5</b>	TA 10	1										
	TA 15											
	TA 25											
	TA 35											
<b>6</b>	TA 10	1										
	TA 15											
	TA 25											
	TA 35											
<b>7</b>	TA 10	1										
	TA 15											
	TA 25											
	TA 35											
<b>8</b>	TA 10	1										
	TA 15											
	TA 25											
	TA 35											
<b>9</b>	TA 10	1										
	TA 15											
	TA 25											
	TA 35											
<b>10</b>	TA 10	1										
	TA 15											
	TA 25											
	TA 35											
<b>12</b>	TA 10	1										
	TA 15											
	TA 25											
	TA 35											

 Angoli di camma realizzabili  
*Feasible cam angles*

 Angoli di camma realizzabili dopo verifica tecnica  
*Cam angles feasible after technical check*



# STAZIONI E ANGOLI DI TRASFERIMENTO

## *Index number and cam transfer angles*

Divisioni Stations	Divisore Indexer	profili camma Cam profiles	Angoli impegnati per lo spostamento Cam rotation angle performing the transfer movements									
			90	120	150	180	210	240	270	300	315	330
<b>14</b>	TA 10	1										
	TA 15											
	TA 25											
	TA 35											
<b>15</b>	TA 10	1										
	TA 15											
	TA 25											
	TA 35											
<b>16</b>	TA 10	2										
	TA 15	1										
	TA 25											
	TA 35											
<b>18</b>	TA 10	2										
	TA 15	1										
	TA 25											
	TA 35											
<b>20</b>	TA 10	2										
	TA 15											
	TA 25											
	TA 35											
<b>24</b>	TA 10	2										
	TA 15											
	TA 25											
	TA 35											
<b>28</b>	TA 10	2										
	TA 15											
	TA 25											
	TA 35											
<b>30</b>	TA 10	3										
	TA 15	2										
	TA 25											
	TA 35											
<b>32</b>	TA 10	2										
	TA 15											
	TA 25											
	TA 35											
<b>36</b>	TA 10	3										
	TA 15	2										
	TA 25											
	TA 35											

 Angoli di camma realizzabili  
*Feasible cam angles*

 Angoli di camma realizzabili dopo verifica tecnica  
*Cam angles feasible after technical check*



# DATI TECNICI Technical data



## CARICHI SUL DISCO ROTANTE Loads on indexing disc

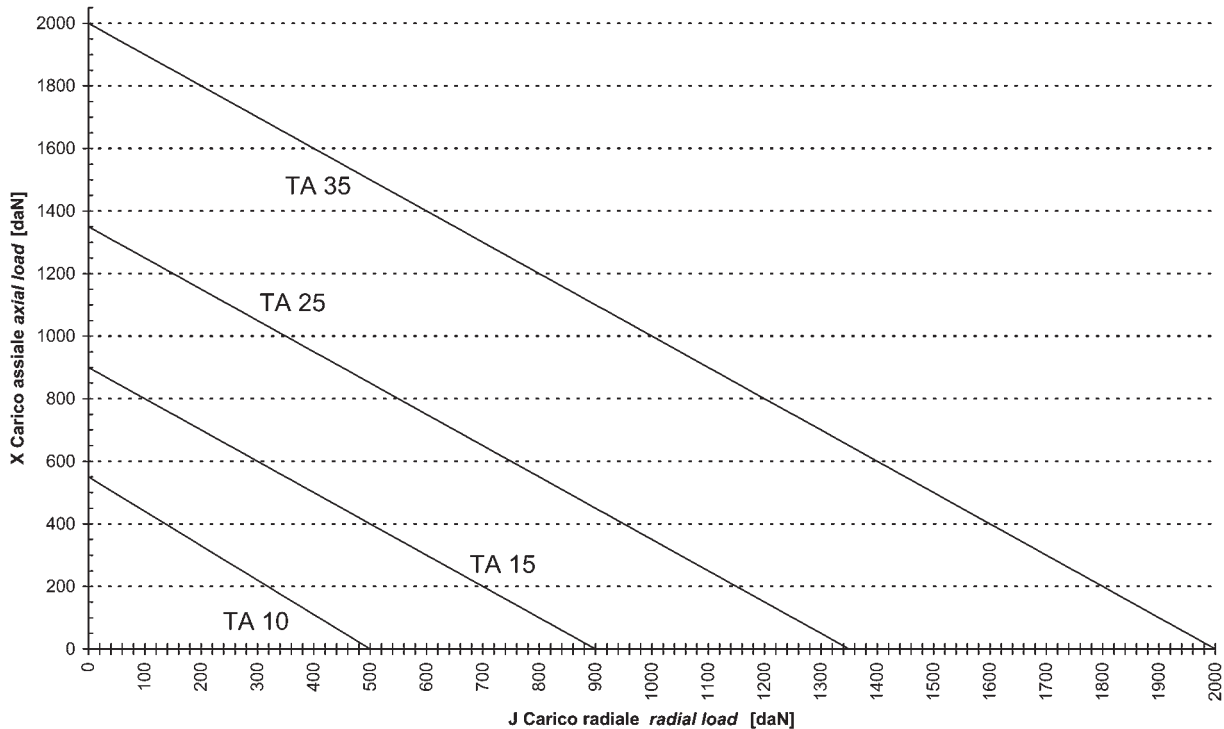

Divisore	Carico assiale X daN	Carico radiale J daN	M. flettente (Y <sub>f</sub> ·R) daNm	M. ribaltante (Y <sub>r</sub> ·R) daNm
TA10	550	500	15	15
TA15	900	900	25	25
TA25	1350	1350	55	55
TA35	2000	2000	90	90

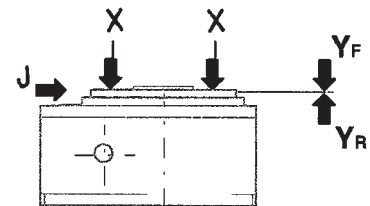

## TOLLERANZE TAVOLE ROTANTI Tolerances of rotary index tables

Divisore Indexer	Ripetibilità Repeatability		Planarità disco Disc flatness		Eccentricità disco Disc eccentricity	
	R (mm)	EE (mm)	∅A (mm)	(mm)	∅B (mm)	(mm)
TA 10	37.5	±0.02	120	0.010	30	0.010
TA 15	50	±0.02	130	0.010	65	0.010
TA 25	80	±0.02	195	0.010	80	0.010
TA 35	100	±0.02	250	0.015	130	0.015

A richiesta / On request EE = ± 0.01

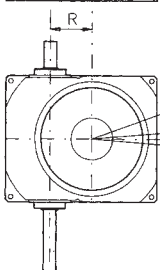
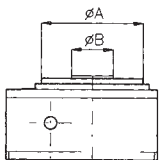

$$Er = \frac{r}{R} \cdot EE \quad (\text{Errore di ripetibilità Repeatability tolerance})$$



# TEMPI DI SPOSTAMENTO

## Index time

R. riduzione <i>R. ratio</i>	Cicli/min <i>Cycles/min</i>	Tempo Ciclo <i>Cycle time</i>	tempo di spostamento (s) riferito all'angolo di camma (°)									
			<i>Index time (s) referred to cam angle (°)</i>									
			(s)	90	120	150	180	210	240	270	300	315
7/1	200.00	0.30	0.075	0.100	0.125	0.150	0.175	0.200	0.225	0.250	0.263	0.275
<b>10/1</b>	<b>140.00</b>	<b>0.43</b>	<b>0.107</b>	<b>0.143</b>	<b>0.179</b>	<b>0.214</b>	<b>0.250</b>	<b>0.286</b>	<b>0.321</b>	<b>0.357</b>	<b>0.375</b>	<b>0.393</b>
<i>13/1</i>	<i>107.69</i>	<i>0.56</i>	<i>0.139</i>	<i>0.186</i>	<i>0.232</i>	<i>0.279</i>	<i>0.325</i>	<i>0.371</i>	<i>0.418</i>	<i>0.464</i>	<i>0.488</i>	<i>0.511</i>
15/1	93.33	0.64	0.161	0.214	0.268	0.321	0.375	0.429	0.482	0.536	0.563	0.589
<b>16/1</b>	<b>87.50</b>	<b>0.69</b>	<b>0.171</b>	<b>0.229</b>	<b>0.286</b>	<b>0.343</b>	<b>0.400</b>	<b>0.457</b>	<b>0.514</b>	<b>0.571</b>	<b>0.600</b>	<b>0.629</b>
<b>20/1</b>	<b>70.00</b>	<b>0.86</b>	<b>0.214</b>	<b>0.286</b>	<b>0.357</b>	<b>0.429</b>	<b>0.500</b>	<b>0.571</b>	<b>0.643</b>	<b>0.714</b>	<b>0.750</b>	<b>0.786</b>
<b>25/1</b>	<b>56.00</b>	<b>1.07</b>	<b>0.268</b>	<b>0.357</b>	<b>0.446</b>	<b>0.536</b>	<b>0.625</b>	<b>0.714</b>	<b>0.804</b>	<b>0.893</b>	<b>0.938</b>	<b>0.982</b>
28/1	50.00	1.20	0.300	0.400	0.500	0.600	0.700	0.800	0.900	1.000	1.050	1.100
<i>30/1</i>	<i>46.67</i>	<i>1.29</i>	<i>0.321</i>	<i>0.429</i>	<i>0.536</i>	<i>0.643</i>	<i>0.750</i>	<i>0.857</i>	<i>0.964</i>	<i>1.071</i>	<i>1.125</i>	<i>1.179</i>
<b>32/1</b>	<b>43.75</b>	<b>1.37</b>	<b>0.343</b>	<b>0.457</b>	<b>0.571</b>	<b>0.686</b>	<b>0.800</b>	<b>0.914</b>	<b>1.029</b>	<b>1.143</b>	<b>1.200</b>	<b>1.257</b>
<b>40/1</b>	<b>35.00</b>	<b>1.71</b>	<b>0.429</b>	<b>0.571</b>	<b>0.714</b>	<b>0.857</b>	<b>1.000</b>	<b>1.143</b>	<b>1.286</b>	<b>1.429</b>	<b>1.500</b>	<b>1.571</b>
<i>40.64 (2.54x16) /1</i>	<i>34.45</i>	<i>1.74</i>	<i>0.435</i>	<i>0.581</i>	<i>0.726</i>	<i>0.871</i>	<i>1.016</i>	<i>1.161</i>	<i>1.306</i>	<i>1.451</i>	<i>1.524</i>	<i>1.597</i>
49/1	28.57	2.10	0.525	0.700	0.875	1.050	1.225	1.400	1.575	1.750	1.838	1.925
<i>50/1</i>	<i>28.00</i>	<i>2.14</i>	<i>0.536</i>	<i>0.714</i>	<i>0.893</i>	<i>1.071</i>	<i>1.250</i>	<i>1.429</i>	<i>1.607</i>	<i>1.786</i>	<i>1.875</i>	<i>1.964</i>
<b>50.8 (2.54x20) /1</b>	<b>27.56</b>	<b>2.18</b>	<b>0.544</b>	<b>0.726</b>	<b>0.907</b>	<b>1.089</b>	<b>1.270</b>	<b>1.451</b>	<b>1.633</b>	<b>1.814</b>	<b>1.905</b>	<b>1.996</b>
56/1	25.00	2.40	0.600	0.800	1.000	1.200	1.400	1.600	1.800	2.000	2.100	2.200
<i>63/1</i>	<i>22.22</i>	<i>2.70</i>	<i>0.675</i>	<i>0.900</i>	<i>1.125</i>	<i>1.350</i>	<i>1.575</i>	<i>1.800</i>	<i>2.025</i>	<i>2.250</i>	<i>2.363</i>	<i>2.475</i>
<b>63.5 (2.54x25) /1</b>	<b>22.05</b>	<b>2.72</b>	<b>0.680</b>	<b>0.907</b>	<b>1.134</b>	<b>1.361</b>	<b>1.588</b>	<b>1.814</b>	<b>2.041</b>	<b>2.268</b>	<b>2.381</b>	<b>2.495</b>
70/1	20.00	3.00	0.750	1.000	1.250	1.500	1.750	2.000	2.250	2.500	2.625	2.750
80/1	17.50	3.43	0.857	1.143	1.429	1.714	2.000	2.286	2.571	2.857	3.000	3.143
<b>81.28 (2.54x32) /1</b>	<b>17.22</b>	<b>3.48</b>	<b>0.871</b>	<b>1.161</b>	<b>1.451</b>	<b>1.742</b>	<b>2.032</b>	<b>2.322</b>	<b>2.613</b>	<b>2.903</b>	<b>3.048</b>	<b>3.193</b>
100/1	14.00	4.29	1.071	1.429	1.786	2.143	2.500	2.857	3.214	3.571	3.750	3.929
<b>101.6 (2.54x40) /1</b>	<b>13.78</b>	<b>4.35</b>	<b>1.089</b>	<b>1.451</b>	<b>1.814</b>	<b>2.177</b>	<b>2.540</b>	<b>2.903</b>	<b>3.266</b>	<b>3.629</b>	<b>3.810</b>	<b>3.991</b>
110/1	12.73	4.71	1.179	1.571	1.964	2.357	2.750	3.143	3.536	3.929	4.125	4.321
<i>120/1</i>	<i>11.67</i>	<i>5.14</i>	<i>1.286</i>	<i>1.714</i>	<i>2.143</i>	<i>2.571</i>	<i>3.000</i>	<i>3.429</i>	<i>3.857</i>	<i>4.286</i>	<i>4.500</i>	<i>4.714</i>
<i>127.00 (2.54x50) /1</i>	<i>11.02</i>	<i>5.44</i>	<i>1.361</i>	<i>1.814</i>	<i>2.268</i>	<i>2.721</i>	<i>3.175</i>	<i>3.629</i>	<i>4.082</i>	<i>4.536</i>	<i>4.763</i>	<i>4.989</i>
130/1	10.77	5.57	1.393	1.857	2.321	2.786	3.250	3.714	4.179	4.643	4.875	5.107
<i>160.02 (2.54x63) /1</i>	<i>8.75</i>	<i>6.86</i>	<i>1.715</i>	<i>2.286</i>	<i>2.858</i>	<i>3.429</i>	<i>4.001</i>	<i>4.572</i>	<i>5.144</i>	<i>5.715</i>	<i>6.001</i>	<i>6.287</i>
<i>197.19 (3.13x63) /1</i>	<i>7.10</i>	<i>8.45</i>	<i>2.113</i>	<i>2.817</i>	<i>3.521</i>	<i>4.226</i>	<i>4.930</i>	<i>5.634</i>	<i>6.338</i>	<i>7.043</i>	<i>7.395</i>	<i>7.747</i>
<i>200/1</i>	<i>7.00</i>	<i>8.57</i>	<i>2.143</i>	<i>2.857</i>	<i>3.571</i>	<i>4.286</i>	<i>5.000</i>	<i>5.714</i>	<i>6.429</i>	<i>7.143</i>	<i>7.500</i>	<i>7.857</i>
220/1	6.36	9.43	2.357	3.143	3.929	4.714	5.500	6.286	7.071	7.857	8.250	8.643
<i>250/1</i>	<i>5.60</i>	<i>10.71</i>	<i>2.679</i>	<i>3.571</i>	<i>4.464</i>	<i>5.357</i>	<i>6.250</i>	<i>7.143</i>	<i>8.036</i>	<i>8.929</i>	<i>9.375</i>	<i>9.821</i>
<i>300/1</i>	<i>4.67</i>	<i>12.86</i>	<i>3.214</i>	<i>4.286</i>	<i>5.357</i>	<i>6.429</i>	<i>7.500</i>	<i>8.571</i>	<i>9.643</i>	<i>10.714</i>	<i>11.250</i>	<i>11.786</i>
<i>400/1</i>	<i>3.50</i>	<i>17.14</i>	<i>4.286</i>	<i>5.714</i>	<i>7.143</i>	<i>8.571</i>	<i>10.000</i>	<i>11.429</i>	<i>12.857</i>	<i>14.286</i>	<i>15.000</i>	<i>15.714</i>
<i>460/1</i>	<i>3.04</i>	<i>19.71</i>	<i>4.929</i>	<i>6.571</i>	<i>8.214</i>	<i>9.857</i>	<i>11.500</i>	<i>13.143</i>	<i>14.786</i>	<i>16.429</i>	<i>17.250</i>	<i>18.071</i>

### RAPPORTI DI RIDUZIONE

Consigliato = **carattere grassetto**  
 Standard = carattere normale  
 Non standard = carattere corsivo sottolineato

### REDUCTION RATIO

*Advised* = **bold character**  
*Standard* = normal character  
*Not standard* = underlined italic character

# TEMPI DI SPOSTAMENTO

## Index time



	R. riduzione <i>R. ratio</i>	Cicli/min <i>Cycles/min</i>	Tempo Ciclo <i>Cycle time</i> (s)	tempo di spostamento (s) riferito all'angolo di camma (°) <i>Index time (s) referred to cam angle (°)</i>									
				90	120	150	180	210	240	270	300	315	330
	7/1	128.57	0.47	0.117	0.156	0.194	0.233	0.272	0.311	0.350	0.389	0.408	0.428
	10/1	90.00	0.67	0.167	0.222	0.278	0.333	0.389	0.444	0.500	0.556	0.583	0.611
	<u>13/1</u>	<u>69.23</u>	<u>0.87</u>	<u>0.217</u>	<u>0.289</u>	<u>0.361</u>	<u>0.433</u>	<u>0.506</u>	<u>0.578</u>	<u>0.650</u>	<u>0.722</u>	<u>0.758</u>	<u>0.794</u>
	15/1	60.00	1.00	0.250	0.333	0.417	0.500	0.583	0.667	0.750	0.833	0.875	0.917
	16/1	56.25	1.07	0.267	0.356	0.444	0.533	0.622	0.711	0.800	0.889	0.933	0.978
	20/1	45.00	1.33	0.333	0.444	0.556	0.667	0.778	0.889	1.000	1.111	1.167	1.222
	25/1	36.00	1.67	0.417	0.556	0.694	0.833	0.972	1.111	1.250	1.389	1.458	1.528
	28/1	32.14	1.87	0.467	0.622	0.778	0.933	1.089	1.244	1.400	1.556	1.633	1.711
	<u>30/1</u>	<u>30.00</u>	<u>2.00</u>	<u>0.500</u>	<u>0.667</u>	<u>0.833</u>	<u>1.000</u>	<u>1.167</u>	<u>1.333</u>	<u>1.500</u>	<u>1.667</u>	<u>1.750</u>	<u>1.833</u>
	32/1	28.13	2.13	0.533	0.711	0.889	1.067	1.244	1.422	1.600	1.778	1.867	1.956
	40/1	22.50	2.67	0.667	0.889	1.111	1.333	1.556	1.778	2.000	2.222	2.333	2.444
	<u>40.64 (2.54x16) /1</u>	<u>22.15</u>	<u>2.71</u>	<u>0.677</u>	<u>0.903</u>	<u>1.129</u>	<u>1.355</u>	<u>1.580</u>	<u>1.806</u>	<u>2.032</u>	<u>2.258</u>	<u>2.371</u>	<u>2.484</u>
	49/1	18.37	3.27	0.817	1.089	1.361	1.633	1.906	2.178	2.450	2.722	2.858	2.994
	<u>50/1</u>	<u>18.00</u>	<u>3.33</u>	<u>0.833</u>	<u>1.111</u>	<u>1.389</u>	<u>1.667</u>	<u>1.944</u>	<u>2.222</u>	<u>2.500</u>	<u>2.778</u>	<u>2.917</u>	<u>3.056</u>
900 rpm	50.8 (2.54x20) /1	17.72	3.39	0.847	1.129	1.411	1.693	1.976	2.258	2.540	2.822	2.963	3.104
	56/1	16.07	3.73	0.933	1.244	1.556	1.867	2.178	2.489	2.800	3.111	3.267	3.422
	<u>63/1</u>	<u>14.29</u>	<u>4.20</u>	<u>1.050</u>	<u>1.400</u>	<u>1.750</u>	<u>2.100</u>	<u>2.450</u>	<u>2.800</u>	<u>3.150</u>	<u>3.500</u>	<u>3.675</u>	<u>3.850</u>
63.5 (2.54x25) /1	14.17	4.23	1.058	1.411	1.764	2.117	2.469	2.822	3.175	3.528	3.704	3.881	
6 p. 50 hz	70/1	12.86	4.67	1.167	1.556	1.944	2.333	2.722	3.111	3.500	3.889	4.083	4.278
	80/1	11.25	5.33	1.333	1.778	2.222	2.667	3.111	3.556	4.000	4.444	4.667	4.889
	81.28 (2.54x32) /1	11.07	5.42	1.355	1.806	2.258	2.709	3.161	3.612	4.064	4.516	4.741	4.967
	100/1	9.00	6.67	1.667	2.222	2.778	3.333	3.889	4.444	5.000	5.556	5.833	6.111
	101.6 (2.54x40) /1	8.86	6.77	1.693	2.258	2.822	3.387	3.951	4.516	5.080	5.644	5.927	6.209
	110/1	8.18	7.33	1.833	2.444	3.056	3.667	4.278	4.889	5.500	6.111	6.417	6.722
	<u>120/1</u>	<u>7.50</u>	<u>8.00</u>	<u>2.000</u>	<u>2.667</u>	<u>3.333</u>	<u>4.000</u>	<u>4.667</u>	<u>5.333</u>	<u>6.000</u>	<u>6.667</u>	<u>7.000</u>	<u>7.333</u>
	<u>127.00 (2.54x50) /1</u>	<u>7.09</u>	<u>8.47</u>	<u>2.117</u>	<u>2.822</u>	<u>3.528</u>	<u>4.233</u>	<u>4.939</u>	<u>5.644</u>	<u>6.350</u>	<u>7.056</u>	<u>7.408</u>	<u>7.761</u>
	130/1	6.92	8.67	2.167	2.889	3.611	4.333	5.056	5.778	6.500	7.222	7.583	7.944
	<u>160.02 (2.54x63) /1</u>	<u>5.62</u>	<u>10.67</u>	<u>2.667</u>	<u>3.556</u>	<u>4.445</u>	<u>5.334</u>	<u>6.223</u>	<u>7.112</u>	<u>8.001</u>	<u>8.890</u>	<u>9.335</u>	<u>9.779</u>
	<u>197.19 (3.13x63) /1</u>	<u>4.56</u>	<u>13.15</u>	<u>3.287</u>	<u>4.382</u>	<u>5.478</u>	<u>6.573</u>	<u>7.669</u>	<u>8.764</u>	<u>9.860</u>	<u>10.955</u>	<u>11.503</u>	<u>12.051</u>
	<u>200/1</u>	<u>4.50</u>	<u>13.33</u>	<u>3.333</u>	<u>4.444</u>	<u>5.556</u>	<u>6.667</u>	<u>7.778</u>	<u>8.889</u>	<u>10.000</u>	<u>11.111</u>	<u>11.667</u>	<u>12.222</u>
220/1	4.09	14.67	3.667	4.889	6.111	7.333	8.556	9.778	11.000	12.222	12.833	13.444	
<u>250/1</u>	<u>3.60</u>	<u>16.67</u>	<u>4.167</u>	<u>5.556</u>	<u>6.944</u>	<u>8.333</u>	<u>9.722</u>	<u>11.111</u>	<u>12.500</u>	<u>13.889</u>	<u>14.583</u>	<u>15.278</u>	
<u>300/1</u>	<u>3.00</u>	<u>20.00</u>	<u>5.000</u>	<u>6.667</u>	<u>8.333</u>	<u>10.000</u>	<u>11.667</u>	<u>13.333</u>	<u>15.000</u>	<u>16.667</u>	<u>17.500</u>	<u>18.333</u>	
<u>400/1</u>	<u>2.25</u>	<u>26.67</u>	<u>6.667</u>	<u>8.889</u>	<u>11.111</u>	<u>13.333</u>	<u>15.556</u>	<u>17.778</u>	<u>20.000</u>	<u>22.222</u>	<u>23.333</u>	<u>24.444</u>	
<u>460/1</u>	<u>1.96</u>	<u>30.67</u>	<u>7.667</u>	<u>10.222</u>	<u>12.778</u>	<u>15.333</u>	<u>17.889</u>	<u>20.444</u>	<u>23.000</u>	<u>25.556</u>	<u>26.833</u>	<u>28.111</u>	

### RAPPORTI DI RIDUZIONE

Consigliato = **carattere grassetto**  
 Standard = *carattere normale*  
 Non standard = carattere corsivo sottolineato

### REDUCTION RATIO

Advised = **bold character**  
 Standard = *normal character*  
 Not standard = underlined italic character



# TEMPI DI SPOSTAMENTO

## Index time

	R. riduzione <i>R. ratio</i>	Cicli/min <i>Cycles/min</i>	Tempo Ciclo <i>Cycle time</i> (s)	tempo di spostamento (s) riferito all'angolo di camma (°)									
				<i>Index time (s) referred to cam angle (°)</i>									
				90	120	150	180	210	240	270	300	315	330
1750 rpm  4 p. 60 hz	7/1	250.00	0.24	0.060	0.080	0.100	0.120	0.140	0.160	0.180	0.200	0.210	0.220
	<b>10/1</b>	<b>175.00</b>	<b>0.34</b>	<b>0.086</b>	<b>0.114</b>	<b>0.143</b>	<b>0.171</b>	<b>0.200</b>	<b>0.229</b>	<b>0.257</b>	<b>0.286</b>	<b>0.300</b>	<b>0.314</b>
	<u>13/1</u>	<u>134.62</u>	<u>0.45</u>	<u>0.111</u>	<u>0.149</u>	<u>0.186</u>	<u>0.223</u>	<u>0.260</u>	<u>0.297</u>	<u>0.334</u>	<u>0.371</u>	<u>0.390</u>	<u>0.409</u>
	15/1	116.67	0.51	0.129	0.171	0.214	0.257	0.300	0.343	0.386	0.429	0.450	0.471
	<b>16/1</b>	<b>109.38</b>	<b>0.55</b>	<b>0.137</b>	<b>0.183</b>	<b>0.229</b>	<b>0.274</b>	<b>0.320</b>	<b>0.366</b>	<b>0.411</b>	<b>0.457</b>	<b>0.480</b>	<b>0.503</b>
	<b>20/1</b>	<b>87.50</b>	<b>0.69</b>	<b>0.171</b>	<b>0.229</b>	<b>0.286</b>	<b>0.343</b>	<b>0.400</b>	<b>0.457</b>	<b>0.514</b>	<b>0.571</b>	<b>0.600</b>	<b>0.629</b>
	<b>25/1</b>	<b>70.00</b>	<b>0.86</b>	<b>0.214</b>	<b>0.286</b>	<b>0.357</b>	<b>0.429</b>	<b>0.500</b>	<b>0.571</b>	<b>0.643</b>	<b>0.714</b>	<b>0.750</b>	<b>0.786</b>
	28/1	62.50	0.96	0.240	0.320	0.400	0.480	0.560	0.640	0.720	0.800	0.840	0.880
	<u>30/1</u>	<u>58.33</u>	<u>1.03</u>	<u>0.257</u>	<u>0.343</u>	<u>0.429</u>	<u>0.514</u>	<u>0.600</u>	<u>0.686</u>	<u>0.771</u>	<u>0.857</u>	<u>0.900</u>	<u>0.943</u>
	<b>32/1</b>	<b>54.69</b>	<b>1.10</b>	<b>0.274</b>	<b>0.366</b>	<b>0.457</b>	<b>0.549</b>	<b>0.640</b>	<b>0.731</b>	<b>0.823</b>	<b>0.914</b>	<b>0.960</b>	<b>1.006</b>
	<b>40/1</b>	<b>43.75</b>	<b>1.37</b>	<b>0.343</b>	<b>0.457</b>	<b>0.571</b>	<b>0.686</b>	<b>0.800</b>	<b>0.914</b>	<b>1.029</b>	<b>1.143</b>	<b>1.200</b>	<b>1.257</b>
	<u>40.64 (2.54x16) /1</u>	<u>43.06</u>	<u>1.39</u>	<u>0.348</u>	<u>0.464</u>	<u>0.581</u>	<u>0.697</u>	<u>0.813</u>	<u>0.929</u>	<u>1.045</u>	<u>1.161</u>	<u>1.219</u>	<u>1.277</u>
	49/1	35.71	1.68	0.420	0.560	0.700	0.840	0.980	1.120	1.260	1.400	1.470	1.540
	<u>50/1</u>	<u>35.00</u>	<u>1.71</u>	<u>0.429</u>	<u>0.571</u>	<u>0.714</u>	<u>0.857</u>	<u>1.000</u>	<u>1.143</u>	<u>1.286</u>	<u>1.429</u>	<u>1.500</u>	<u>1.571</u>
	<b>50.8 (2.54x20) /1</b>	<b>34.45</b>	<b>1.74</b>	<b>0.435</b>	<b>0.581</b>	<b>0.726</b>	<b>0.871</b>	<b>1.016</b>	<b>1.161</b>	<b>1.306</b>	<b>1.451</b>	<b>1.524</b>	<b>1.597</b>
	56/1	31.25	1.92	0.480	0.640	0.800	0.960	1.120	1.280	1.440	1.600	1.680	1.760
	<u>63/1</u>	<u>27.78</u>	<u>2.16</u>	<u>0.540</u>	<u>0.720</u>	<u>0.900</u>	<u>1.080</u>	<u>1.260</u>	<u>1.440</u>	<u>1.620</u>	<u>1.800</u>	<u>1.890</u>	<u>1.980</u>
	<b>63.5 (2.54x25) /1</b>	<b>27.56</b>	<b>2.18</b>	<b>0.544</b>	<b>0.726</b>	<b>0.907</b>	<b>1.089</b>	<b>1.270</b>	<b>1.451</b>	<b>1.633</b>	<b>1.814</b>	<b>1.905</b>	<b>1.996</b>
	70/1	25.00	2.40	0.600	0.800	1.000	1.200	1.400	1.600	1.800	2.000	2.100	2.200
	80/1	21.88	2.74	0.686	0.914	1.143	1.371	1.600	1.829	2.057	2.286	2.400	2.514
	<b>81.28 (2.54x32) /1</b>	<b>21.53</b>	<b>2.79</b>	<b>0.697</b>	<b>0.929</b>	<b>1.161</b>	<b>1.393</b>	<b>1.626</b>	<b>1.858</b>	<b>2.090</b>	<b>2.322</b>	<b>2.438</b>	<b>2.555</b>
	100/1	17.50	3.43	0.857	1.143	1.429	1.714	2.000	2.286	2.571	2.857	3.000	3.143
	<b>101.6 (2.54x40) /1</b>	<b>17.22</b>	<b>3.48</b>	<b>0.871</b>	<b>1.161</b>	<b>1.451</b>	<b>1.742</b>	<b>2.032</b>	<b>2.322</b>	<b>2.613</b>	<b>2.903</b>	<b>3.048</b>	<b>3.193</b>
	110/1	15.91	3.77	0.943	1.257	1.571	1.886	2.200	2.514	2.829	3.143	3.300	3.457
	<u>120/1</u>	<u>14.58</u>	<u>4.11</u>	<u>1.029</u>	<u>1.371</u>	<u>1.714</u>	<u>2.057</u>	<u>2.400</u>	<u>2.743</u>	<u>3.086</u>	<u>3.429</u>	<u>3.600</u>	<u>3.771</u>
	<u>127.00 (2.54x50) /1</u>	<u>13.78</u>	<u>4.35</u>	<u>1.089</u>	<u>1.451</u>	<u>1.814</u>	<u>2.177</u>	<u>2.540</u>	<u>2.903</u>	<u>3.266</u>	<u>3.629</u>	<u>3.810</u>	<u>3.991</u>
	130/1	13.46	4.46	1.114	1.486	1.857	2.229	2.600	2.971	3.343	3.714	3.900	4.086
	<u>160.02 (2.54x63) /1</u>	<u>10.94</u>	<u>5.49</u>	<u>1.372</u>	<u>1.829</u>	<u>2.286</u>	<u>2.743</u>	<u>3.200</u>	<u>3.658</u>	<u>4.115</u>	<u>4.572</u>	<u>4.801</u>	<u>5.029</u>
	<u>197.19 (3.13x63) /1</u>	<u>8.87</u>	<u>6.76</u>	<u>1.690</u>	<u>2.254</u>	<u>2.817</u>	<u>3.380</u>	<u>3.944</u>	<u>4.507</u>	<u>5.071</u>	<u>5.634</u>	<u>5.916</u>	<u>6.197</u>
	<u>200/1</u>	<u>8.75</u>	<u>6.86</u>	<u>1.714</u>	<u>2.286</u>	<u>2.857</u>	<u>3.429</u>	<u>4.000</u>	<u>4.571</u>	<u>5.143</u>	<u>5.714</u>	<u>6.000</u>	<u>6.286</u>
220/1	7.95	7.54	1.886	2.514	3.143	3.771	4.400	5.029	5.657	6.286	6.600	6.914	
<u>250/1</u>	<u>7.00</u>	<u>8.57</u>	<u>2.143</u>	<u>2.857</u>	<u>3.571</u>	<u>4.286</u>	<u>5.000</u>	<u>5.714</u>	<u>6.429</u>	<u>7.143</u>	<u>7.500</u>	<u>7.857</u>	
<u>300/1</u>	<u>5.83</u>	<u>10.29</u>	<u>2.571</u>	<u>3.429</u>	<u>4.286</u>	<u>5.143</u>	<u>6.000</u>	<u>6.857</u>	<u>7.714</u>	<u>8.571</u>	<u>9.000</u>	<u>9.429</u>	
<u>400/1</u>	<u>4.38</u>	<u>13.71</u>	<u>3.429</u>	<u>4.571</u>	<u>5.714</u>	<u>6.857</u>	<u>8.000</u>	<u>9.143</u>	<u>10.286</u>	<u>11.429</u>	<u>12.000</u>	<u>12.571</u>	
<u>460/1</u>	<u>3.80</u>	<u>15.77</u>	<u>3.943</u>	<u>5.257</u>	<u>6.571</u>	<u>7.886</u>	<u>9.200</u>	<u>10.514</u>	<u>11.829</u>	<u>13.143</u>	<u>13.800</u>	<u>14.457</u>	

### RAPPORTI DI RIDUZIONE

Consigliato = **carattere grassetto**  
 Standard = carattere normale  
 Non standard = carattere corsivo sottolineato

### REDUCTION RATIO

*Advised* = **bold character**  
*Standard* = normal character  
*Not standard* = underlined italic character

# TEMPI DI SPOSTAMENTO

## Index time



	R. riduzione <i>R. ratio</i>	Cicli/min <i>Cycles/min</i>	Tempo Ciclo <i>Cycle time</i> (s)	tempo di spostamento (s) riferito all'angolo di camma (°)									
				<i>Index time (s) referred to cam angle (°)</i>									
				90	120	150	180	210	240	270	300	315	330
	7/1	164.29	0.37	0.091	0.122	0.152	0.183	0.213	0.243	0.274	0.304	0.320	0.335
	<b>10/1</b>	<b>115.00</b>	<b>0.52</b>	<b>0.130</b>	<b>0.174</b>	<b>0.217</b>	<b>0.261</b>	<b>0.304</b>	<b>0.348</b>	<b>0.391</b>	<b>0.435</b>	<b>0.457</b>	<b>0.478</b>
	<i>13/1</i>	<i>88.46</i>	<i>0.68</i>	<i>0.170</i>	<i>0.226</i>	<i>0.283</i>	<i>0.339</i>	<i>0.396</i>	<i>0.452</i>	<i>0.509</i>	<i>0.565</i>	<i>0.593</i>	<i>0.622</i>
	15/1	76.67	0.78	0.196	0.261	0.326	0.391	0.457	0.522	0.587	0.652	0.685	0.717
	<b>16/1</b>	<b>71.88</b>	<b>0.83</b>	<b>0.209</b>	<b>0.278</b>	<b>0.348</b>	<b>0.417</b>	<b>0.487</b>	<b>0.557</b>	<b>0.626</b>	<b>0.696</b>	<b>0.730</b>	<b>0.765</b>
	<b>20/1</b>	<b>57.50</b>	<b>1.04</b>	<b>0.261</b>	<b>0.348</b>	<b>0.435</b>	<b>0.522</b>	<b>0.609</b>	<b>0.696</b>	<b>0.783</b>	<b>0.870</b>	<b>0.913</b>	<b>0.957</b>
	<b>25/1</b>	<b>46.00</b>	<b>1.30</b>	<b>0.326</b>	<b>0.435</b>	<b>0.543</b>	<b>0.652</b>	<b>0.761</b>	<b>0.870</b>	<b>0.978</b>	<b>1.087</b>	<b>1.141</b>	<b>1.196</b>
	28/1	41.07	1.46	0.365	0.487	0.609	0.730	0.852	0.974	1.096	1.217	1.278	1.339
	<i>30/1</i>	<i>38.33</i>	<i>1.57</i>	<i>0.391</i>	<i>0.522</i>	<i>0.652</i>	<i>0.783</i>	<i>0.913</i>	<i>1.043</i>	<i>1.174</i>	<i>1.304</i>	<i>1.370</i>	<i>1.435</i>
	<b>32/1</b>	<b>35.94</b>	<b>1.67</b>	<b>0.417</b>	<b>0.557</b>	<b>0.696</b>	<b>0.835</b>	<b>0.974</b>	<b>1.113</b>	<b>1.252</b>	<b>1.391</b>	<b>1.461</b>	<b>1.530</b>
	<b>40/1</b>	<b>28.75</b>	<b>2.09</b>	<b>0.522</b>	<b>0.696</b>	<b>0.870</b>	<b>1.043</b>	<b>1.217</b>	<b>1.391</b>	<b>1.565</b>	<b>1.739</b>	<b>1.826</b>	<b>1.913</b>
	<i>40.64 (2.54x16) /1</i>	<i>28.30</i>	<i>2.12</i>	<i>0.530</i>	<i>0.707</i>	<i>0.883</i>	<i>1.060</i>	<i>1.237</i>	<i>1.414</i>	<i>1.590</i>	<i>1.767</i>	<i>1.855</i>	<i>1.944</i>
	49/1	23.47	2.56	0.639	0.852	1.065	1.278	1.491	1.704	1.917	2.130	2.237	2.343
	<i>50/1</i>	<i>23.00</i>	<i>2.61</i>	<i>0.652</i>	<i>0.870</i>	<i>1.087</i>	<i>1.304</i>	<i>1.522</i>	<i>1.739</i>	<i>1.957</i>	<i>2.174</i>	<i>2.283</i>	<i>2.391</i>
1150 rpm	<b>50.8 (2.54x20) /1</b>	<b>22.64</b>	<b>2.65</b>	<b>0.663</b>	<b>0.883</b>	<b>1.104</b>	<b>1.325</b>	<b>1.546</b>	<b>1.767</b>	<b>1.988</b>	<b>2.209</b>	<b>2.319</b>	<b>2.430</b>
	56/1	20.54	2.92	0.730	0.974	1.217	1.461	1.704	1.948	2.191	2.435	2.557	2.678
	<i>63/1</i>	<i>18.25</i>	<i>3.29</i>	<i>0.822</i>	<i>1.096</i>	<i>1.370</i>	<i>1.643</i>	<i>1.917</i>	<i>2.191</i>	<i>2.465</i>	<i>2.739</i>	<i>2.876</i>	<i>3.013</i>
	<b>63.5 (2.54x25) /1</b>	<b>18.11</b>	<b>3.31</b>	<b>0.828</b>	<b>1.104</b>	<b>1.380</b>	<b>1.657</b>	<b>1.933</b>	<b>2.209</b>	<b>2.485</b>	<b>2.761</b>	<b>2.899</b>	<b>3.037</b>
	70/1	16.43	3.65	0.913	1.217	1.522	1.826	2.130	2.435	2.739	3.043	3.196	3.348
6 p. 60 hz	80/1	14.38	4.17	1.043	1.391	1.739	2.087	2.435	2.783	3.130	3.478	3.652	3.826
	<b>81.28 (2.54x32) /1</b>	<b>14.15</b>	<b>4.24</b>	<b>1.060</b>	<b>1.414</b>	<b>1.767</b>	<b>2.120</b>	<b>2.474</b>	<b>2.827</b>	<b>3.181</b>	<b>3.534</b>	<b>3.711</b>	<b>3.887</b>
	100/1	11.50	5.22	1.304	1.739	2.174	2.609	3.043	3.478	3.913	4.348	4.565	4.783
	<b>101.6 (2.54x40) /1</b>	<b>11.32</b>	<b>5.30</b>	<b>1.325</b>	<b>1.767</b>	<b>2.209</b>	<b>2.650</b>	<b>3.092</b>	<b>3.534</b>	<b>3.976</b>	<b>4.417</b>	<b>4.638</b>	<b>4.859</b>
	110/1	10.45	5.74	1.435	1.913	2.391	2.870	3.348	3.826	4.304	4.783	5.022	5.261
	<i>120/1</i>	<i>9.58</i>	<i>6.26</i>	<i>1.565</i>	<i>2.087</i>	<i>2.609</i>	<i>3.130</i>	<i>3.652</i>	<i>4.174</i>	<i>4.696</i>	<i>5.217</i>	<i>5.478</i>	<i>5.739</i>
	<i>127.00 (2.54X50) /1</i>	<i>9.06</i>	<i>6.63</i>	<i>1.657</i>	<i>2.209</i>	<i>2.761</i>	<i>3.313</i>	<i>3.865</i>	<i>4.417</i>	<i>4.970</i>	<i>5.522</i>	<i>5.798</i>	<i>6.074</i>
	130/1	8.85	6.78	1.696	2.261	2.826	3.391	3.957	4.522	5.087	5.652	5.935	6.217
	<i>160.02 (2.54X63) /1</i>	<i>7.19</i>	<i>8.35</i>	<i>2.087</i>	<i>2.783</i>	<i>3.479</i>	<i>4.174</i>	<i>4.870</i>	<i>5.566</i>	<i>6.262</i>	<i>6.957</i>	<i>7.305</i>	<i>7.653</i>
	<i>197.19 (3.13X63) /1</i>	<i>5.83</i>	<i>10.29</i>	<i>2.572</i>	<i>3.429</i>	<i>4.287</i>	<i>5.144</i>	<i>6.001</i>	<i>6.859</i>	<i>7.716</i>	<i>8.573</i>	<i>9.002</i>	<i>9.431</i>
	<i>200/1</i>	<i>5.75</i>	<i>10.43</i>	<i>2.609</i>	<i>3.478</i>	<i>4.348</i>	<i>5.217</i>	<i>6.087</i>	<i>6.957</i>	<i>7.826</i>	<i>8.696</i>	<i>9.130</i>	<i>9.565</i>
	220/1	5.23	11.48	2.870	3.826	4.783	5.739	6.696	7.652	8.609	9.565	10.043	10.522
	<i>250/1</i>	<i>4.60</i>	<i>13.04</i>	<i>3.261</i>	<i>4.348</i>	<i>5.435</i>	<i>6.522</i>	<i>7.609</i>	<i>8.696</i>	<i>9.783</i>	<i>10.870</i>	<i>11.413</i>	<i>11.957</i>
	<i>300/1</i>	<i>3.83</i>	<i>15.65</i>	<i>3.913</i>	<i>5.217</i>	<i>6.522</i>	<i>7.826</i>	<i>9.130</i>	<i>10.435</i>	<i>11.739</i>	<i>13.043</i>	<i>13.696</i>	<i>14.348</i>
	<i>400/1</i>	<i>2.88</i>	<i>20.87</i>	<i>5.217</i>	<i>6.957</i>	<i>8.696</i>	<i>10.435</i>	<i>12.174</i>	<i>13.913</i>	<i>15.652</i>	<i>17.391</i>	<i>18.261</i>	<i>19.130</i>
	<i>460/1</i>	<i>2.50</i>	<i>24.00</i>	<i>6.000</i>	<i>8.000</i>	<i>10.000</i>	<i>12.000</i>	<i>14.000</i>	<i>16.000</i>	<i>18.000</i>	<i>20.000</i>	<i>21.000</i>	<i>22.000</i>

### RAPPORTI DI RIDUZIONE

Consigliato = **carattere grassetto**  
 Standard = *carattere normale*  
 Non standard = carattere corsivo sottolineato

### REDUCTION RATIO

*Advised* = **bold character**  
*Standard* = *normal character*  
*Not standard* = *underlined italic character*









# TAVOLA ROTANTE ROTARY INDEX TABLE TA 35

PESO / Weight Kg. 84



 ROTANTE  
ROTATING

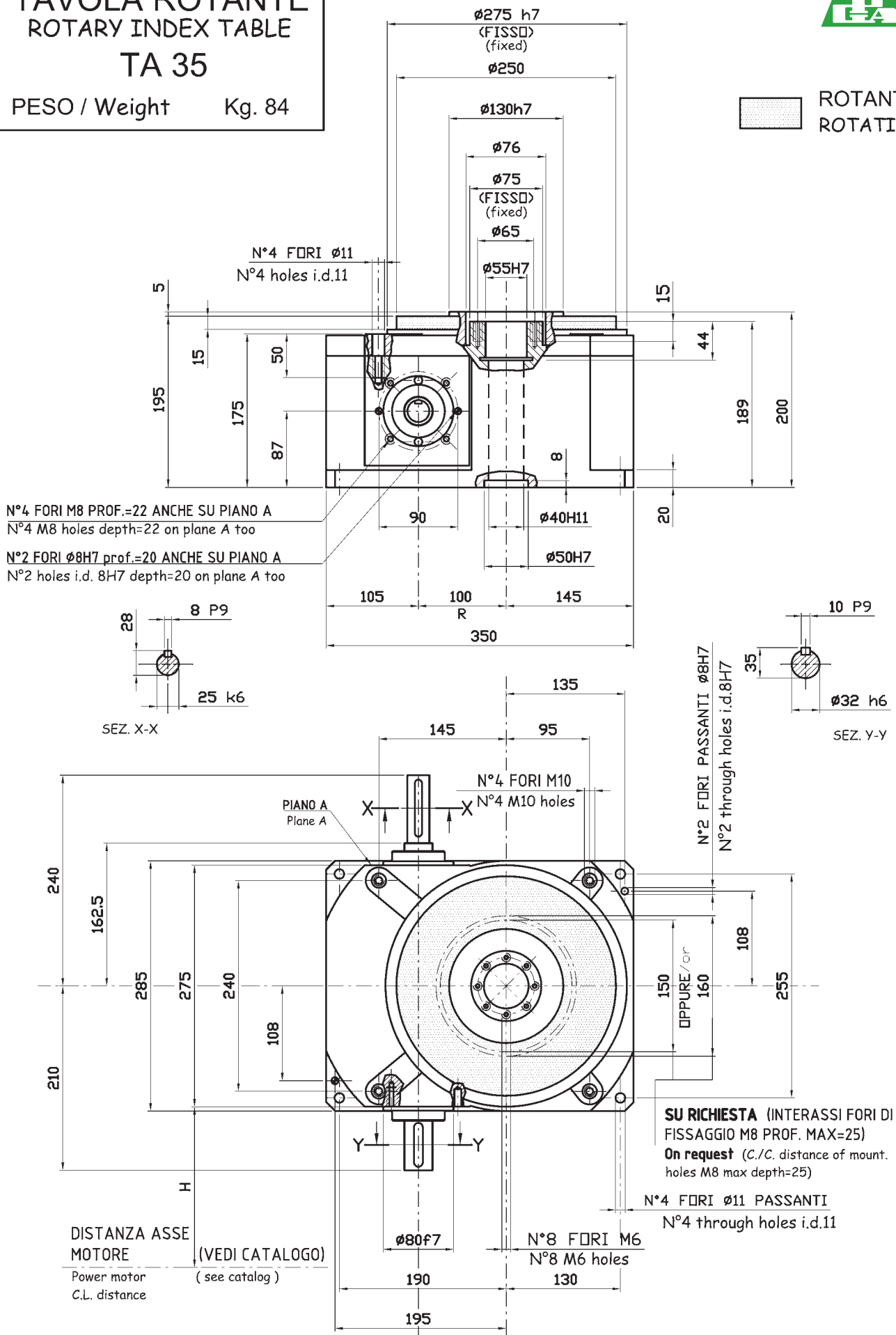



# FORI PER L'ASSEMBLAGGIO SUL DISCO TAVOLA

## Assembling threaded holes on table dial plate

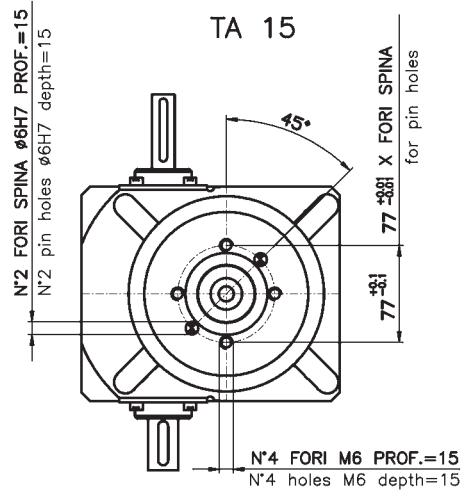
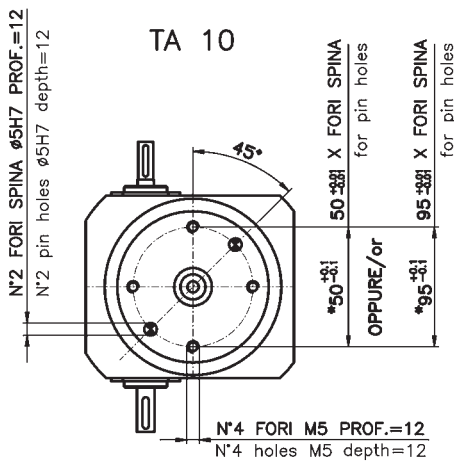

\* PER LA SCELTA DELL'INTERASSE DI FORATURA  
CONSULTARE L'UFFICIO TECNICO  
To select bolt holes circle contact our  
technical office

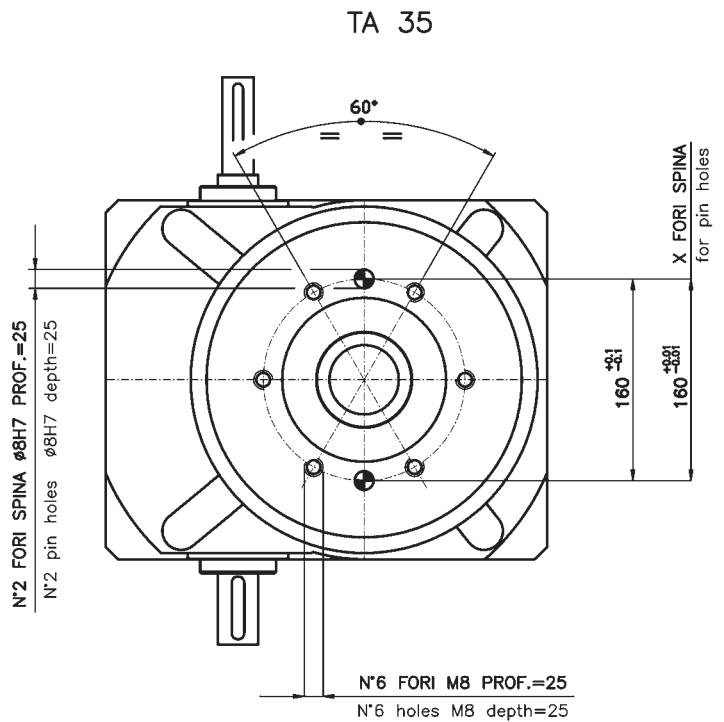
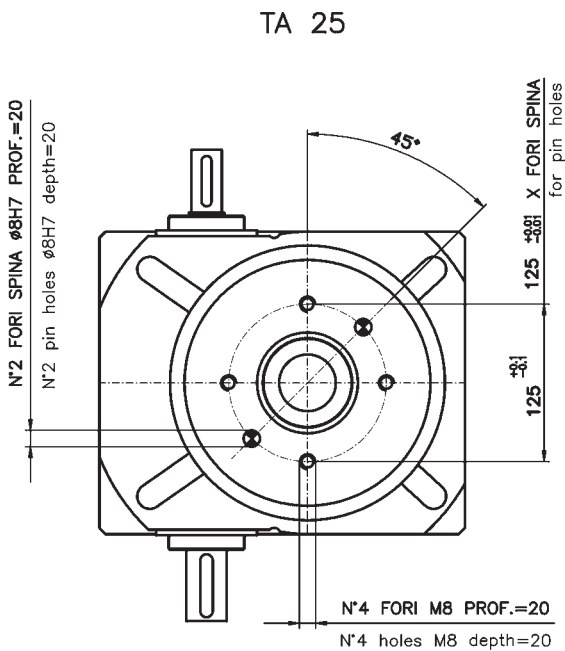

# DIMENSIONI CAMMA E MICRO DI FASE

## Overall dimensions of cam/set microswitch



### MECCANICO

#### Mechanical

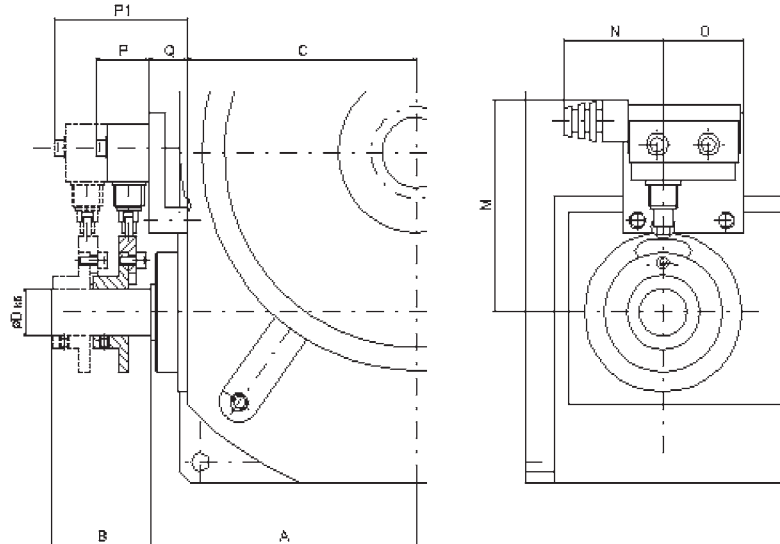

### INDUTTIVO

#### Inductive

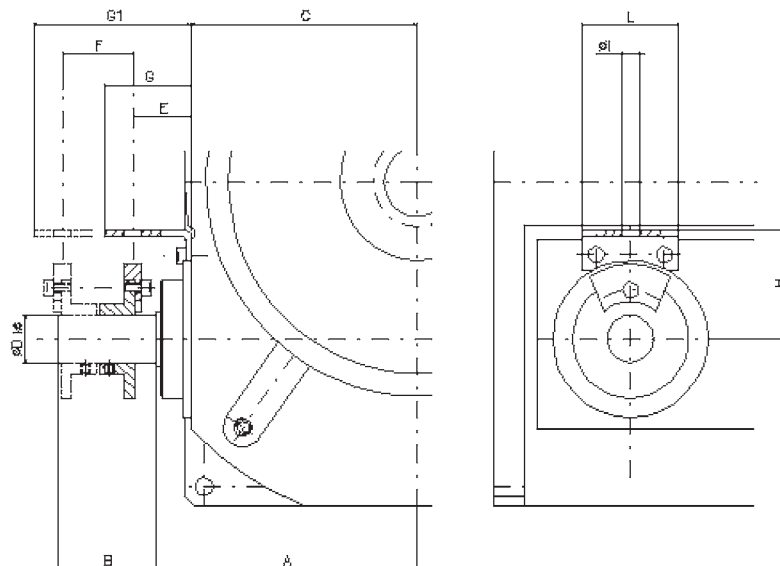

	A	B	C	ØD	E	F	G	G1	H	ØI	L	M	N	O	P	P1	Q
<b>TA10</b>	85	30	75	12	15	32	30	60	55	8.5	44	110	50	40	28	55	5
<b>TA15</b>	99	59	86	18	25	32	40	72	55	8.35	55	110	50	40	28	64	14
<b>TA25</b>	135	50	116.5	24	30	35	50	85	55	8.5	50	110	50	40	28	70	20
<b>TA35</b>	162.5	77.5	137.5	25	30	35	50	85	55	8.5	50	110	50	40	28	70	20



## POSIZIONE DI LAVORO TAVOLA ROTANTE

### *Index table operating position*

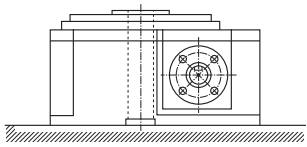
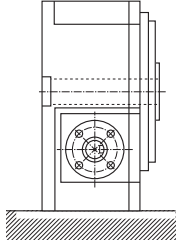
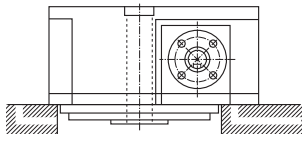
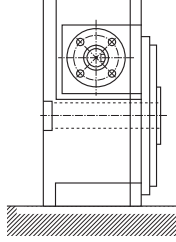
<p><b>STANDARD</b> <i>Standard</i></p> 	<p><b>1 ASSE ORIZZONTALE ALBERO INFERIORE</b> <i>Horizontal axis lower input shaft</i></p>	<p><b>3</b></p> 
<p><b>CAPOVOLTA</b> <i>Upside down</i></p> 	<p><b>2 ASSE ORIZZONTALE ALBERO SUPERIORE</b> <i>Horizontal axis upper input shaft</i></p>	<p><b>4</b></p> 

## POSIZIONE DI MONTAGGIO UNITÀ MOTRICE

### *Power drive unit assembling position*

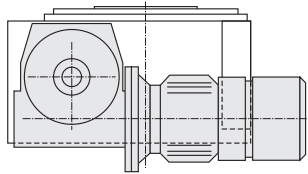
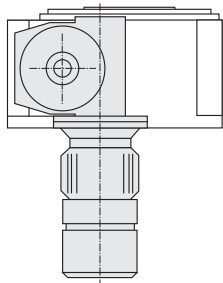
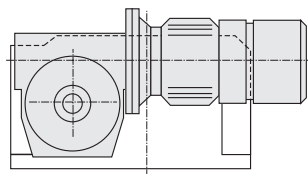
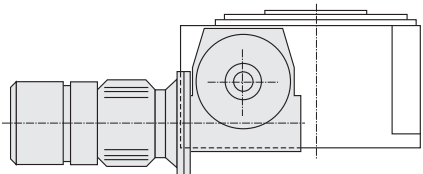
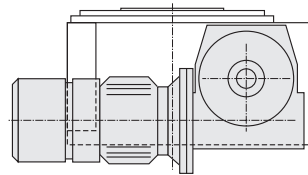
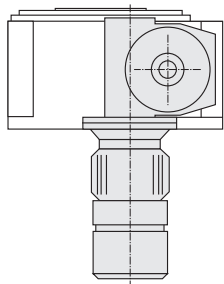
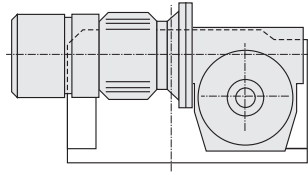
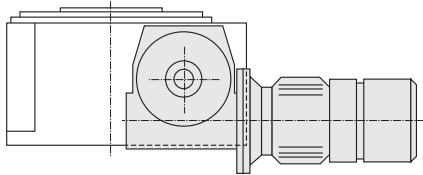
<p><b>MONTAGGIO SUL LATO STANDARD</b> <i>Assembling on standard side</i></p>		
		
<p><b>MONTAGGIO SUL LATO OPPOSTO</b> <i>Assembling on opposite side</i></p>		
		

# RIDUTTORI ROSSI STANDARD RV

## RV ROSSI STANDARD REDUCER

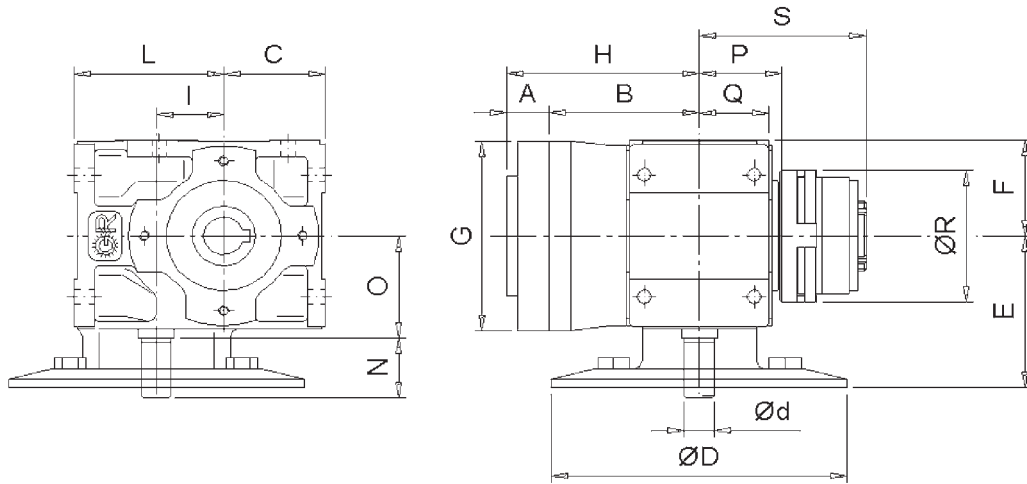

RIDUTTORE	DIVISORE	A	B	C	ØD	E	F	G	H	I	L	Ød	M	N	O	P	Q	R	S	PESO weight Kg
Red type	Indexer																			

					Pam63																	
RV 32	10	18,5																				
	15	34,5	71	48	140		76	48	□95	89,5	32	71	14	j6	M6	25	51	39	33	66	79	5,5
	25	55,5								126,5												
CAD File N°.					540203																	

					Pam63	Pam71																	
RV 40	15	31,5																					
	25	52,5	80	56	140	160		87	55	□110	111,5	40	82	16	j6	M6	30	59,5	46	40	81	93	9
	35	52,5									132,5												
CAD File N°.					540204	540205																	

					Pam63	Pam71	Pam80																	
RV 50	25	60,5	80	67	140	160	200		98	65	Ø160	140,5	50	100	19	j6	M6	30	70,5	53	48	81	100	14
	35																							
CAD File N°.					540206	540207	540208																	

					Pam71	Pam80	Pam90																	
RV 63	25	50,5	100	80	160	200	200		118	78	□155	150,5	63	125	19	j6	M6	40	83	63	57	104	119	23
	35																							
CAD File N°.					540209	540210	540210																	

					Pam80	Pam90	Pam100	Pam112																	
RV 80	25	50,5	112	100	200	200	250	250	138	98	□200	162,5	80	150	24	j6	M8	50	103	75	68	131	143	36	
	35																								
CAD File N°.					540211	540211	540212	540212																	

TA15+RV32

TA15+RV40

TA25+RV50





# RIDOTTORI ROSSI STANDARD RIV

## RIV ROSSI STANDARD REDUCER

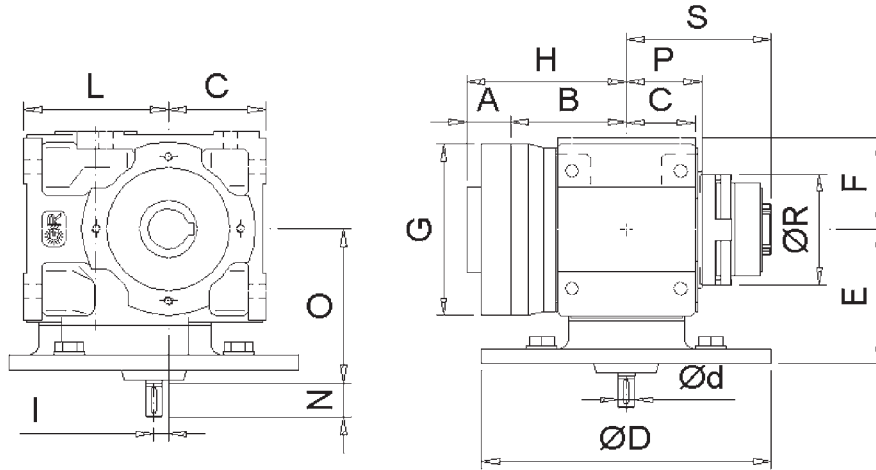

RIDUTTORE	DIVISORE	A	B	C	ØD	E	F	G	H	I	L	Ød	M	N	O	P	Q	R	S	PESO weight Kg	
Red type	Indexer																				

					Pam63																		
<b>RIV 32</b>	10	18,5																					
	15	34,5	71	48	140			76	48	□95	89,5	0	71	11	j6	M5	20	81	39	33	66	79	7,5
	25	55,5									126,5												
CAD File N°.					540222																		

					Pam63	Pam71																	
<b>RIV 40</b>	15	31,5																					
	25	52,5	80	56	140	160		87	55	□110	111,5	0	82	11	j6	M5	23	96	46	40	81	93	11
	35										132,5												
CAD File N°.					540223	540224																	

					Pam63	Pam71	Pam80																	
<b>RIV 50</b>	25	60,5	80	67	140	160	200		98	65	Ø160	140,5	10	100	11	j6	M5	23	107	53	48	81	100	16
	35																							
CAD File N°.					540225	540226	540227																	

					Pam71	Pam80	Pam90																	
<b>RIV 63</b>	25	50,5	100	80	160	200	200		118	78	□155	150,5	13	125	14	j6	M6	30	127	63	57	104	119	26
	35																							
CAD File N°.					540228	540229	540229																	

					Pam80	Pam90	Pam100	Pam112															
<b>RIV 80</b>	25	50,5	112	100	200	200	250	250	138	98	□200	162,5	30	150	14	M6	30	147	75	68	131	143	39
	35																						
CAD File N°.					540230	540230	540231	540231															

Gamma e micro di fase  
Cam/set microswitch

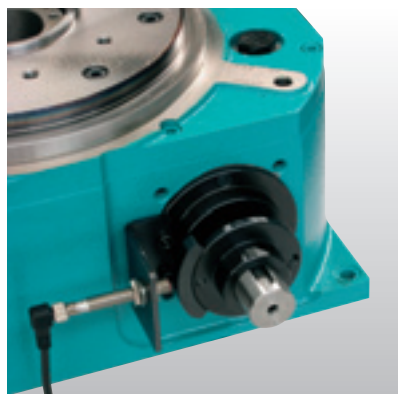

Riduttore con  
limitatore di coppia  
Reducer with torque limiter

# MOTORE ELETTRICO NORMALE

## NORMAL ELECTRIC MOTOR



DIMENSIONE Size	POTENZA KW				ØA	ØB	C	D	E	PESO Weight Kg
	2 POLI	4 POLI	6 POLI	8 POLI						
56	0,09	0,06			120	125	180	110	80	3
	0,12	0,09								
63	0,18	0,12	0,12		140	135	210	110	85	4,5
	0,26	0,18								
	0,37	0,24								
71	0,37	0,26	0,18	0,15	160	150	240	140	100	7
	0,55	0,37	0,26							
80	0,74	0,55	0,37	0,26	200	165	245	150	100	10
	1,1	0,74	0,55							
90S	1,5	1,1	0,75	0,37	200	185	285	160	120	12
90L	1,8	1,5	1,1	0,55	200	185	285	160	120	17
	2,2	1,8								
100	3	2,2	1,5	0,74	250	210	345	180	120	22
	4	3	1,8	1,1						

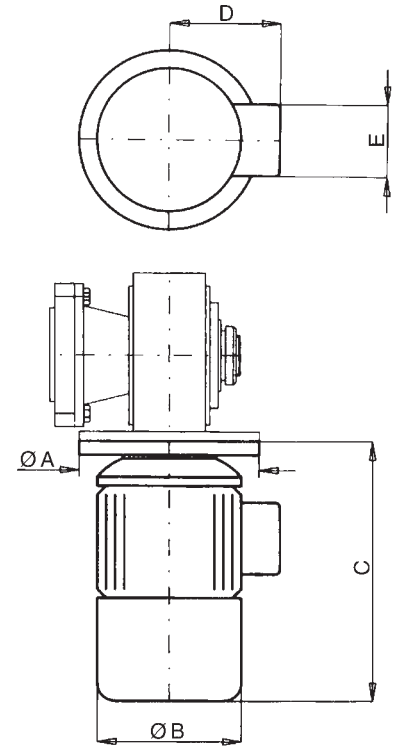

# MOTORE ELETTRICO AUTOFRENANTE

## ELECTRIC BRAKE MOTOR

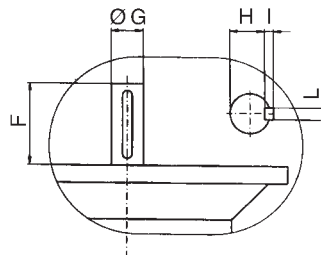

DIM. Size	CAD File n.	POTENZA KW				ØA	ØB	C	D	E	F	ØG	H	I	L	PESO Weight Kg
		2 POLI	4 POLI	6 POLI	8 POLI											
56	540071	0,12	0,06			120	115	200	105	105	20	9	7,2	3	3	4,5
		0,18	0,08													
63	540072	0,25	0,12	0,075		140	130	240	115	105	23	11	8,5	4	4	5,5
		0,33	0,23													
		0,37	0,25													
71	540058	0,55	0,37	0,22	0,15	160	150	320	140	120	30	14	11	5	5	12
		0,75	0,55	0,37												
80	540073	1,1	0,75	0,55	0,25	200	165	340	150	130	40	19	15,5	6	6	16
		0,75	0,55	0,37												
90S	540074	1,5	1,1	0,75	0,37	200	185	370	160	120	50	24	20	7	8	26
		1,84														
90L	540075	2,2	1,5	1,1	0,55	200	185	390	160	120	50	24	20	7	8	28,5
		1,84														
100	540076		2,2	1,5	0,75	250	210	455	185	140	60	28	24	7	8	40

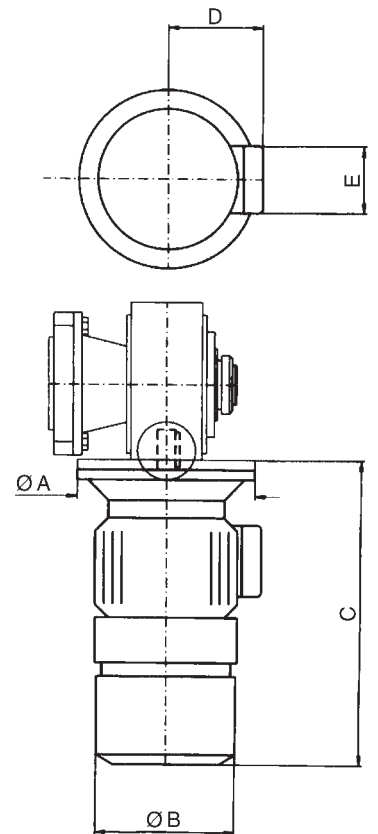

# TAVOLE ROTANTI PNEUMATICHE E UNITÀ COMBinate

## *Pneumatic rotary tables and combined units*

**G.P.A. ITALIANA produce anche, da quarant'anni, tavole rotanti ad azionamento pneumatico, nei seguenti modelli:**  
**G.P.A. ITALIANA manufactures, since forty years now, also pneumatically driven rotary tables, in the following models:**



1



2

1) TAR 270, portata fino a 100 kg, divisore standard per 4 - 6 - 8 - 12 - 24 stazioni selezionabili, altri divisori a richiesta.

1) TAR 270, load up to 100 kg, standard indexes selectable for 4 - 6 - 8 - 12 - 24 stations, other indexes on request.

2) TAR 160, portata fino a 20 kg, divisori standard per 4 - 8 oppure 4 - 6 - 12 stazioni selezionabili.

2) TAR 160, load up to 20 kg, standard indexes selectable for 4 - 8 or 4 - 6 - 12 stations.

**Unità combinate tavola rotante con pressa pneumatica o idropneumatica G.P.A.:**  
**Combined dial feed units with G.P.A. pneumatic or hydropneumatic press:**

3) Tavola pressa TAR 270/PCM 7000 in versione compatta da banco, con pressa da 70 kN, completa di schermi di protezione.

3) Compact bench version rotary table press TAR 270/PCM 7000, with 70 kN press, complete of safety shields.

4) Tavola pressa TAR 270/PRNA 1000, in versione compatta da banco, con pressa da 10 kN, completa di schermi di protezione e banco di supporto.

4) Compact bench version rotary table press TAR 270/PRNA 1000, with 10 kN press, complete of safety shields and support table.



3



4



5



6

5) Tavola pressa TAR 270/PCM 7000, con pressa da 70 kN e manipolatore di scarico.

5) Rotary table press TAR 270/PCM 7000 with 70 kN press and pick and place unit.

6) Unità combinata tavola rotante con due presse pneumatiche e una rivettatrice orbitale.

6) Combined dial feed machine with two hydropneumatic presses and one orbital haedforming unit.

RIVENDITORE AUTORIZZATO  
 AUTHORIZED RETAILER



G.P.A. ITALIANA s.r.l. - Via L. da Vinci, 25 - 22074 Lomazzo (CO) - ITALY

Tel. +39 02 96779406 - Fax +39 02 96370473

E-mail: gpa@gpa-automation.com - www.gpa-automation.com