

QUICK DIE XCHANGE

QDX

Motorized Bolster Extensions

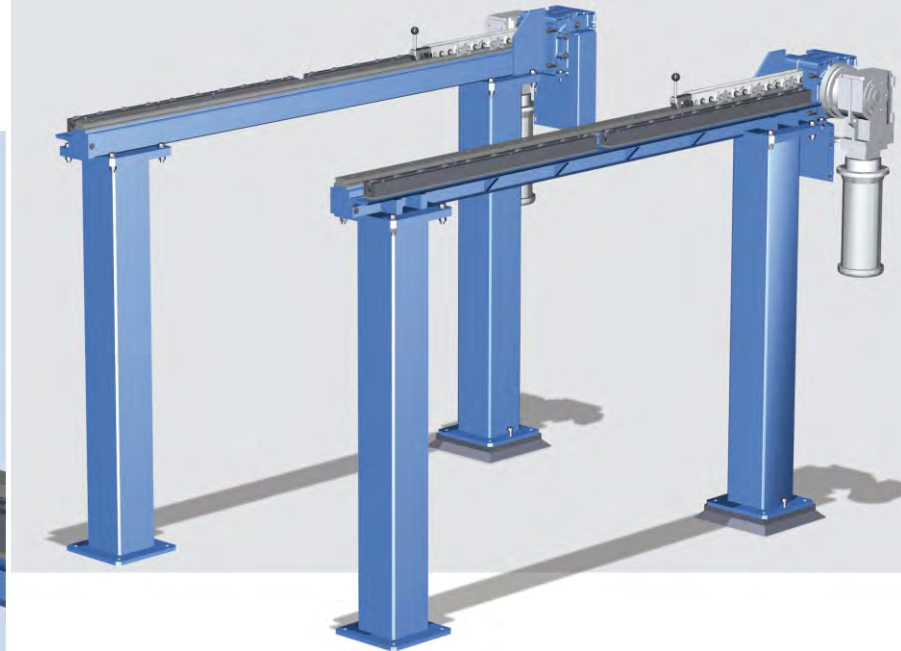
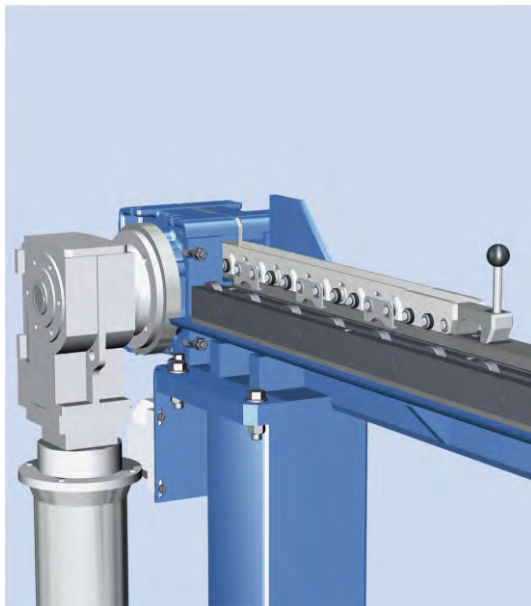

The Motorized Bolster Extensions (MBE) combine the functionality of bolster extensions and push-pull system into one integrated unit. MBEs support the die outside of the press and transfer the die in and out of the press. The die can be loaded with either an overhead crane or a fork-truck. MBEs also allow easy access to the side of the press. Since they are

a small obstruction, part and scrap removal is easy.

The MBEs feature SERAPID's Rigid Chain Technology, which allows the die to be positioned several inches onto the bolster without special attachments. They have a capacity of 10 to 25 tons. Height range is six inches and up.

SERAPID
PUSHING AHEAD

Motorized Bolster Extensions

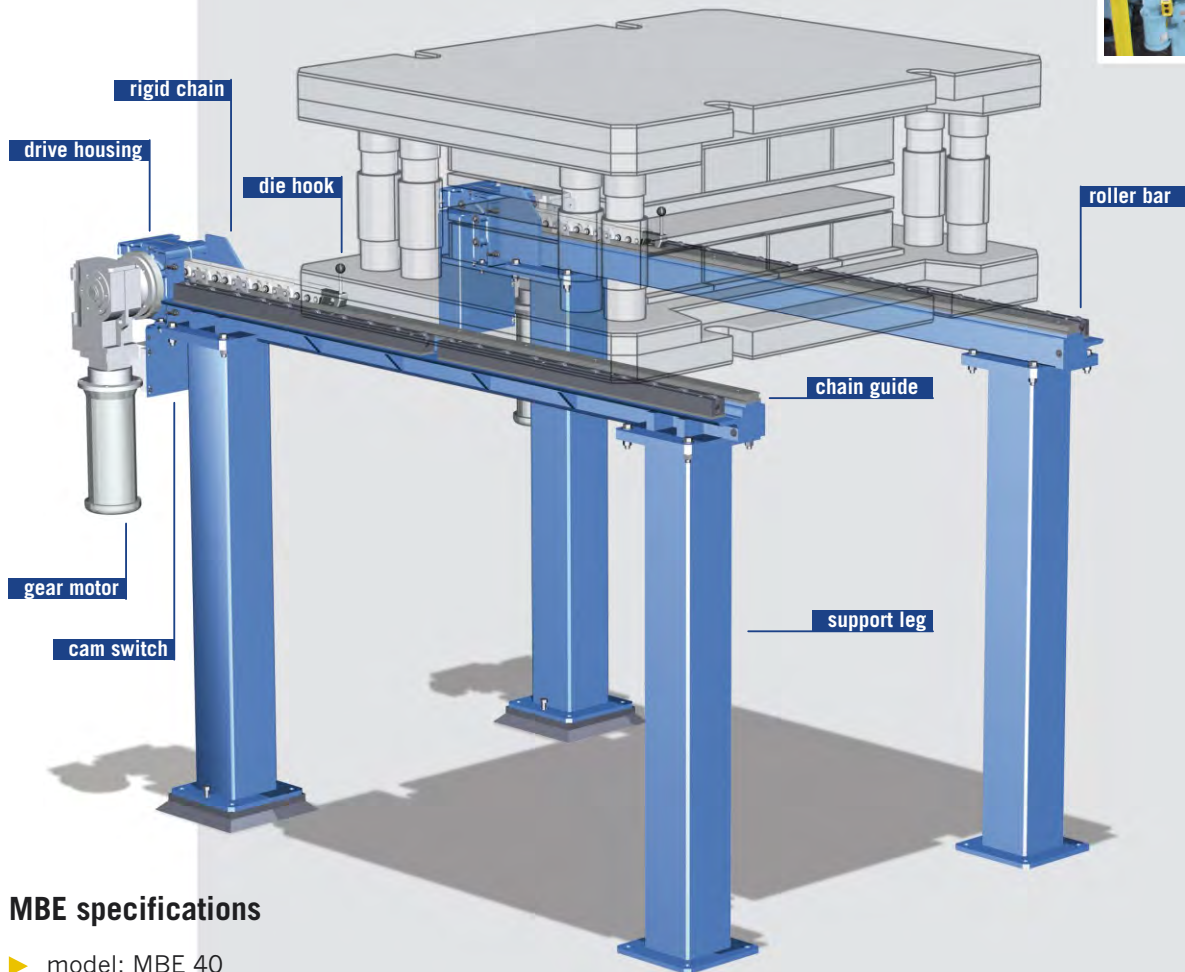

MBE specifications

- ▶ model: MBE 40
- ▶ capacity: up to 15 tons
- ▶ die size: 30 in – 70 in (F-B) x 60 in (L-R)
- ▶ height range: 12 in. – 54 in



www.serapid.com

SERAPID INC.

5400 18 Mile Road
Sterling Heights MI 48314, USA

Phone +1 586 274 0774

Fax +1 586 274 0775

info-us@serapid.com